

The Instruction of the 3-Point Disc Harrow

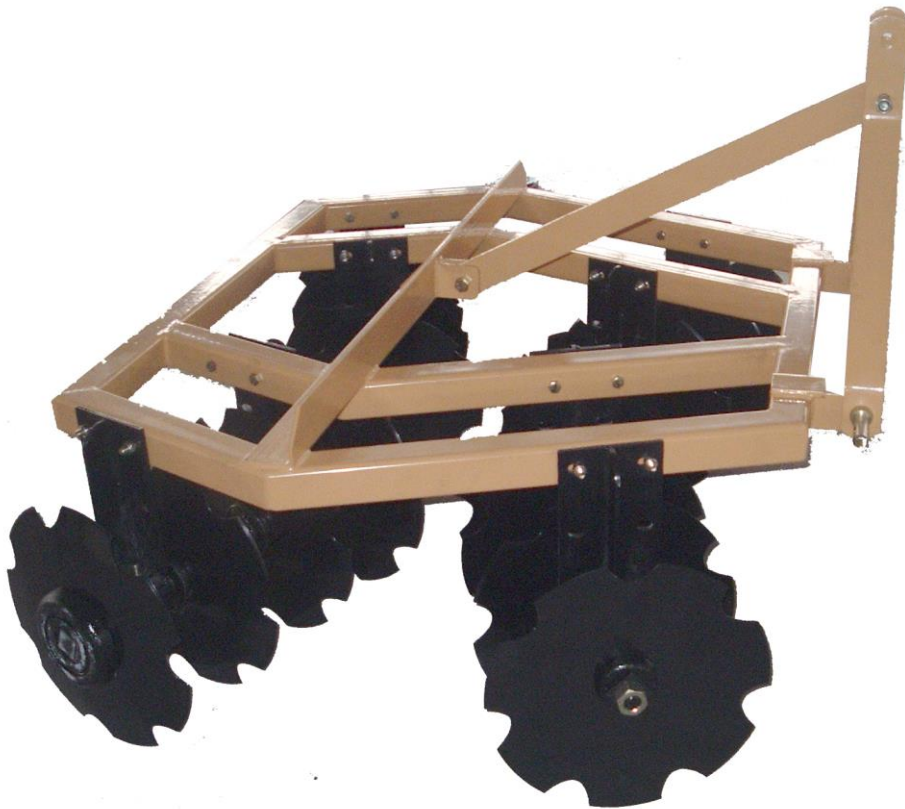

Please Read This Manual BEFORE Using This Tool

CAUTION

THE FOLLOWING SAFETY PRECAUTIONS SHOULD BE THOROUGHLY UNDERSTOOD BEFORE ATTEMPTING TO BEGIN ASSEMBLING THIS MACHINE

1. Select an area for assembly that is clean and free of any debris which might cause persons working on the assembly to trip.
2. Do not lift heavy parts or assemblies. Use crane, jack, tackle, fork trucks or other mechanical devices.
3. Preview the assembly instructions in your operator's manual before proceeding further.
4. If the assembly instructions call for parts or assemblies to be blocked up, use only blocks material that is good condition and is capable of handling the weight of the assembly to be blocked. Also insure that the blocking material is on a clean, dry surface.
5. Never put hands, or any part of body, under blocked up assemblies if at all possible.
6. After completing assembly, thoroughly inspect the machine to be sure that all nuts, bolts, hydraulic fittings or any other fastened assemblies have been thoroughly tightened.
7. Before operating the machine, thoroughly read the operation section of your operator's manual.
8. Before operating, read the machine section of your operator's manual to be sure that any parts requiring lubrication, such as gearbox, to avoid any possible damage.
9. Before operating equipment – if you have any questions regarding the proper assembly or operation, contact you dealer or representative.

EQUIPMENT SAFETY GUIDELINES

1. Never use alcoholic beverages or drugs which can hinder alertness or coordination while operating this equipment. Consult your doctor about operating this machine while taking prescription medications.
2. Review the safety instructions with all users annually.
3. This equipment is dangerous to children and persons unfamiliar with its operation. The operator should be a responsible adult familiar with farm machinery and trained in this equipment's operations. **Do not allow persons to operate or assemble this unit until they have read this manual and have developed a thorough understanding of the safety precautions and of how works.**
4. Do not modify the equipment in any way. Unauthorized modification may impair the function and could affect the life of equipment.

OPERATIONAL SAFETY

1. The use of this equipment is subject to certain hazards which cannot be protected against by mechanical means or product design. All operators of this equipment must read and understand this entire manual, paying particular attention to operating, prior to using. If there is something in this manual you do not understand, ask your supervisor, or your dealer, to explain it to you.
2. Personal protection equipment including hard hat, safety glasses, safety shoes, and gloves are recommended during assembly.
3. Never permit any person other than the operator to ride or board the tractor or implement at any time. **ALLOW NO RIDERS!**
4. Always drive slowly-especially around turns. An unstable tractor could steer badly and possibly tip over, causing injury or death.
5. Most accidents occur because of neglect or carelessness. Keep all helpers and bystanders at a safe distance.

MAINTENANCE SAFETY

1. Keep all persons away from operator control area while performing adjustments, service, or maintenance.
2. Periodically tighten all bolts, nuts and screws and check that all cotter pins are properly installed to ensure unit is in a safe condition.
3. Never use your hands to locate a hydraulic leak on attachments. Use a small piece of cardboard or wood.
4. Never replace hex bolts with less than grade five bolts unless otherwise specified. Refer to bolt torque chart for head identification marking.

STORAGE SAFETY

1. Store the unit in an area away from human activity. Do not permit children to play on or around the stored unit.
2. Make sure all parked machines are on a hard, level surface and engage all safety devices.
3. If blocking is used, make sure it is solid and secure before leaving area.

ALWAYS OBEY ALL SAFETY RULES!

ALWAYS BE CAREFUL!

Disc Harrow Parts Assembly

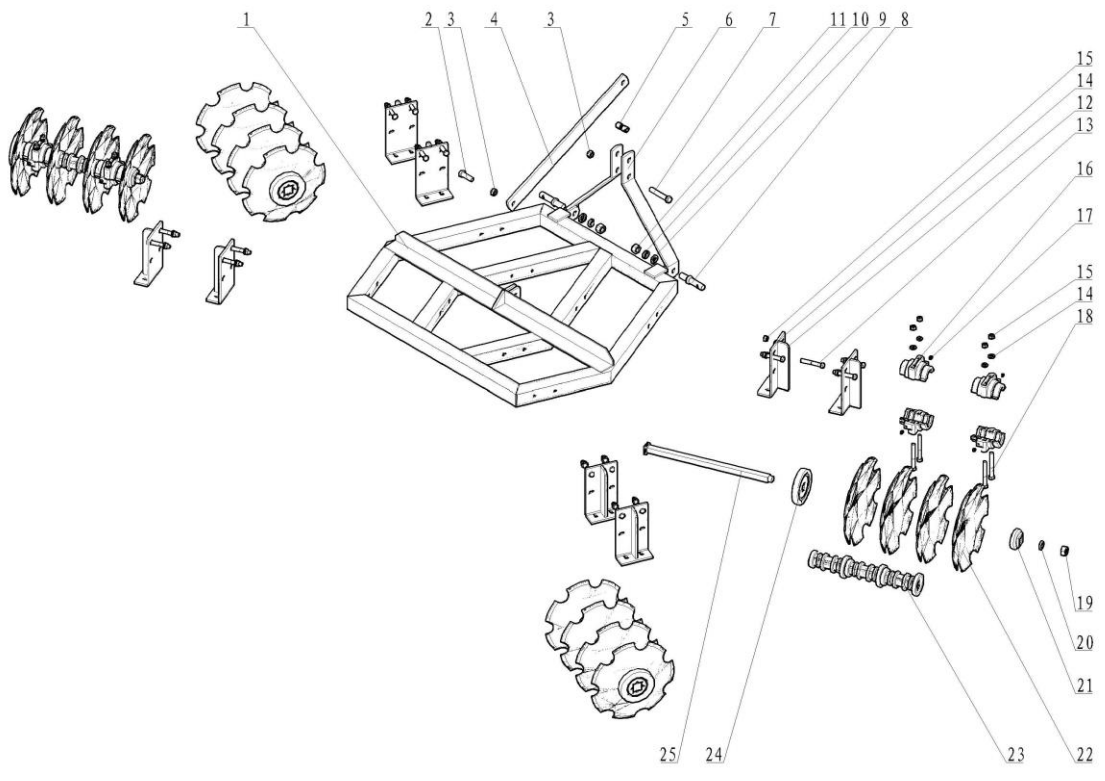

Parts List

| Index | Description | Quantity |
|--------------|--------------------|-----------------|
| 1 | Disc Harrow Frame | 1 |
| 2 | Bolt M16×50 | 1 |
| 3 | Lock Nut M16 | 2 |
| 4 | A-Frame Brace | 1 |
| 5 | Spacer | 2 |
| 6 | A Frame | 2 |
| 7 | Bolt M16×100 | 1 |
| 8 | Lift Pin | 2 |
| 9 | Flat Washer 22 | 2 |
| 10 | Spring Washer 22 | 2 |
| 11 | Nut M22 | 2 |
| 12 | Disc Depth Bracket | 8 |
| 13 | Bolt M12×90 | 16 |
| 14 | Flat Washer 12 | 32 |
| 15 | Lock Nut M12 | 32 |
| 16 | Hub Mounting Body | 8 |
| 17 | Grease Fitting | 16 |
| 18 | Bolt M12×140 | 16 |
| 19 | Nut M24 | 4 |
| 20 | Spring Washer 24 | 4 |
| 21 | Inner Hub End | 4 |
| 22 | Disc | 16 |
| 23 | Hub Axle | 12 |
| 24 | Outer Hub End | 4 |
| 25 | Axle Shaft | 4 |